

Ad-A-Beam™ for Ku Band Uplink/Downlink

Anticipated Technical Specification Brief

Ad-A-Beam (**Ad**aptive **Analog Beam**forming) delivers high performance Ku band beamforming for phased array antennas at 10 to 20 times lower cost than existing solutions. Phased arrays offer better flexibility, performance, and maintenance costs than reflector antennas, but existing array signal processing systems require either flexibility-limiting and costly phase-only analog beamforming or powerful but even more expensive digital beamforming. For broadband applications such as satellite television or internet access where the link margin dictates arrays with dozens or hundreds of elements, traditional analog beamforming with discrete parts or digital sampling are impractical. Ad-A-Beam is the first beamformer technology to reduce per-element costs sufficiently to enable fully adaptive phased arrays for the multi-dwelling unit (MDU), mobile, and commercial Ku band satellite television and internet access markets.

Ad-A-Beam's hybrid approach combines advantages of both analog and digital architectures. Analog signal paths deliver low cost broadband performance. Amplitude control allows an inexpensive, external, single-channel DSP/controller to interrogate the signal space and perform closed-loop, adaptive source tracking without having to sample each array branch simultaneously. On-chip continuous phase and amplitude control provides full vector modulation for maximum beam pattern control.

Highlights

- 4 TX/RX branches per chip
- Standard Ku band uplink/downlink frequencies
- Continuous phase and amplitude control (full vector modulation)
- Integrated upconversion/downconversion
- Both discrete and integrated LNA and PA possible
- Scalable for large arrays with numerous antenna elements
- Custom designs for other bands possible with 9 month lead time

Functional Block Diagram

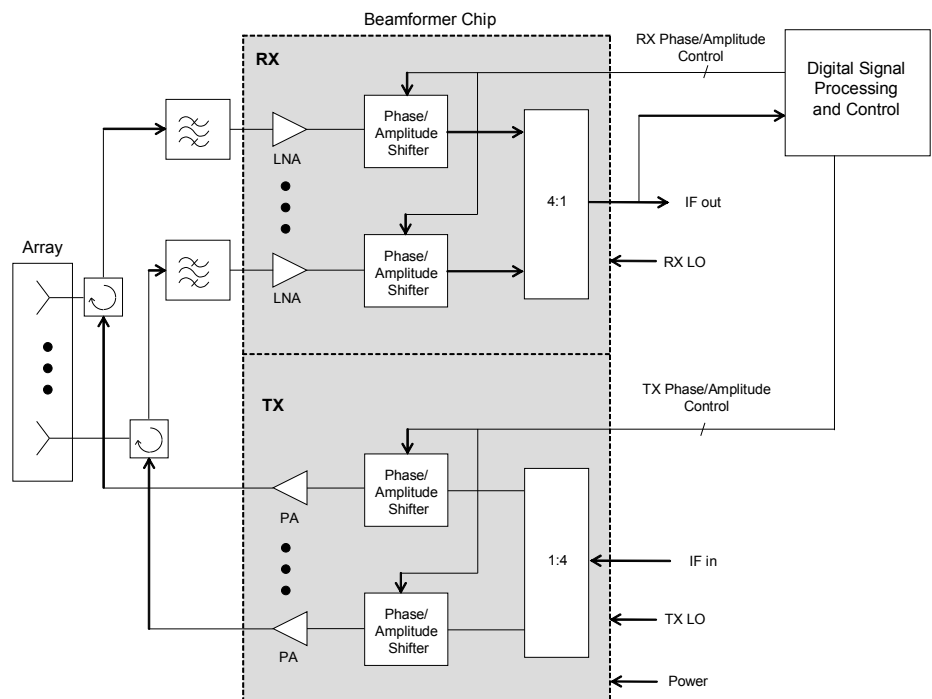

Anticipated Specifications

Number of TX/RX branches	4	
RX frequency	11.7 – 12.7 Ghz	Ku band downlink
IF ouput frequency	950-1950 MHz	
RX bandwidth	500 MHz	
RX gain	15 dB	Gain for one branch at maximum amplitude
Noise figure	3 dB	Integrated LNAs provide second gain stage. 1 dB NF requires off-chip LNA.
TX frequency	13.75-14.5 GHz	Ku band uplink
IF input frequency	1800-2550 MHz	
TX bandwidth	500 MHz	
RF output power per channel	20 mW	Coherent beamforming on transmit allows full-power beam to be realized with low RF power per array element driver.
TX Gain	15 dB	Gain for one branch at maximum amplitude control (LNA gain reduced by conversion loss).
Power supply voltage	+12 V	

Number of Pins
RX: 4 RF inputs 8 control lines 1 LO input 1 IF output
TX: 4 RF outputs 8 control lines 1 LO input 1 IF input
DC: 1 Power supply 1 Ground
30 pins total

Ad-A-Beam offers compelling price points competing technologies may not reach perhaps for a decade, granting immediate access to otherwise unreachable broader and richer consumer markets.

An illustration of Ad-A-Beam cost savings

Consider if a phased array antenna was desired for receiving the Dish500™ satellite television programming through a shared master antenna (SMA) for a 100-unit apartment building. About 200 low gain antenna elements are needed for a wide sky-view and required gain. Let's assume just three concurrent, "always on" 500 Mhz satellite signals. If 500Mhz equals 1Gbps processing capacity, a **digital beamforming solution** will need $200 \times 3 \times 1 = 600$ Gbps of processing. At \$100 per Gbps of processing (a presently unachievable low cost), the DSP costs alone would reach \$60,000. Amortized per unit over 2 years, the per unit monthly charge for beamforming is **\$25.00**. Well over the \$5 monthly cost allocated for the whole antenna.

If a phase only **analog beamforming solution** is pursued, instead, with \$40 ferroelectric phase shifters, the beamforming costs come to $200 \times 3 \times \$40 = \$24,000$ and this solution does not perform dynamic beam shaping. Amortized as above, this beamforming cost line comes to **\$10.00** per month per unit.

An Ad-A-Beam solution delivers beam steering and beam shaping in an analog solution at approximately \$10.00 per beam per element. Ad-A-Beam reduces beamforming costs to $200 \times 3 \times \$10 = \6000 . The beamforming would cost just **\$2.50** per unit per month.

Note 1: There are many reasons why a \$6000 to \$10,000 phased array may be chosen over multiple fixed elliptical reflectors including far better signal quality, municipal codes, lower installation and maintenance costs, alternative programming potentials from mobile or fixed orbital sources, alternative broadband sourcing, etc.

Note 2: A receive-only configuration using 8 channel chips with integrated LNA would have a retail antenna cost of \$3000 to \$4000.